

ADVANCED ENERGY RETROFIT RFP WIZARD

Muscoe Martin, AIA, LEED

Department of Architecture
University of Pennsylvania
School of Design

MuscoeM@design.upenn.edu

Muscoe@m2-arch.com



Goal, Vision, and Mission



OVERALL GOAL:

Reduce annual energy use in the Greater Philadelphia commercial buildings sector by 20 percent by 2020.

VISION:

Design, demonstrate and deploy market proven solutions in the Greater Philadelphia region so that the buildings sector accomplishes its full potential for ongoing energy efficiency.

MISSION:

Accomplish the goal through informed people, validated information, and proven technologies.

Energy Efficiency in Buildings

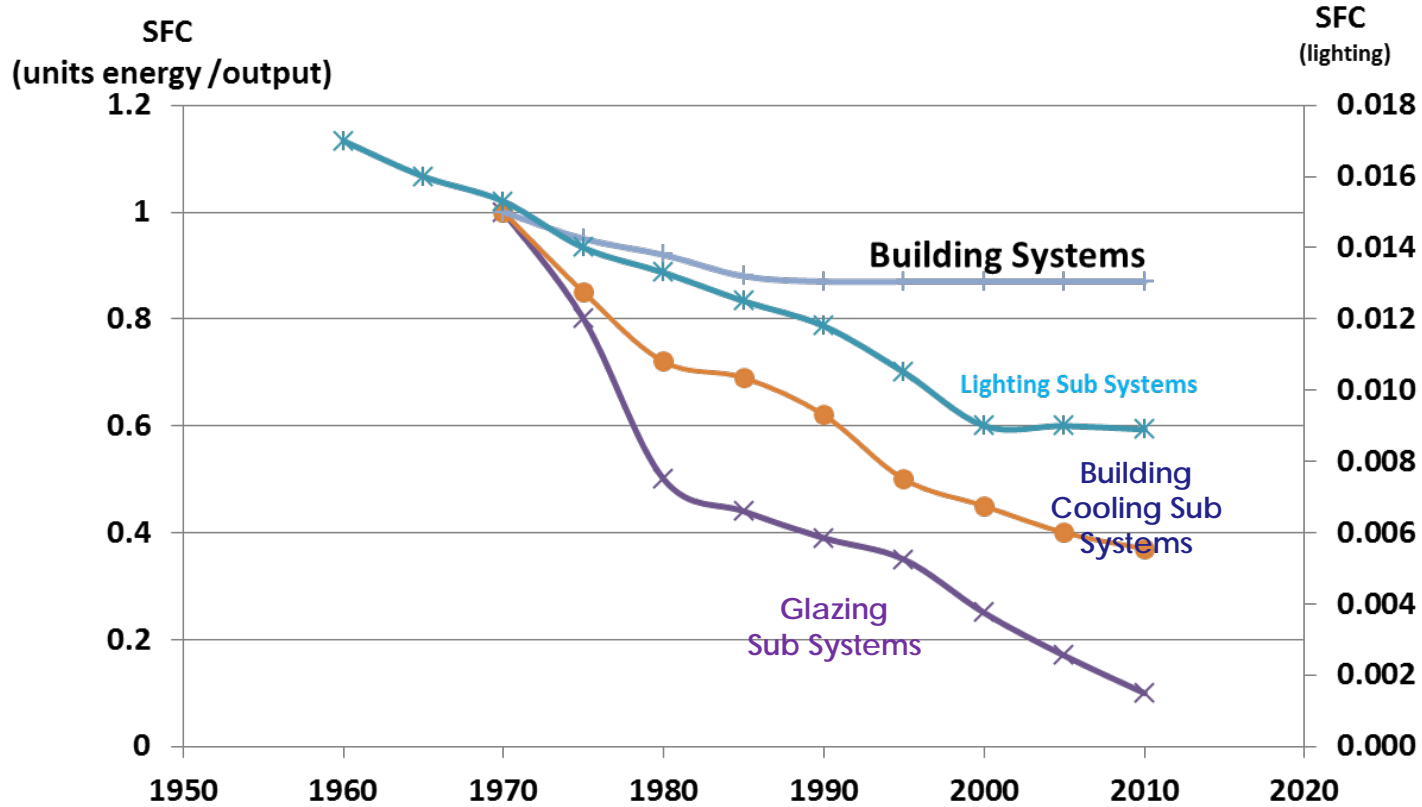

Building Sector Accounts for :

40% of Total U.S. Prime Energy Expended
70% of all U.S. Electric Energy Use



ADVANCED ENERGY RETROFIT (AER) BUILDING AS A SYSTEM

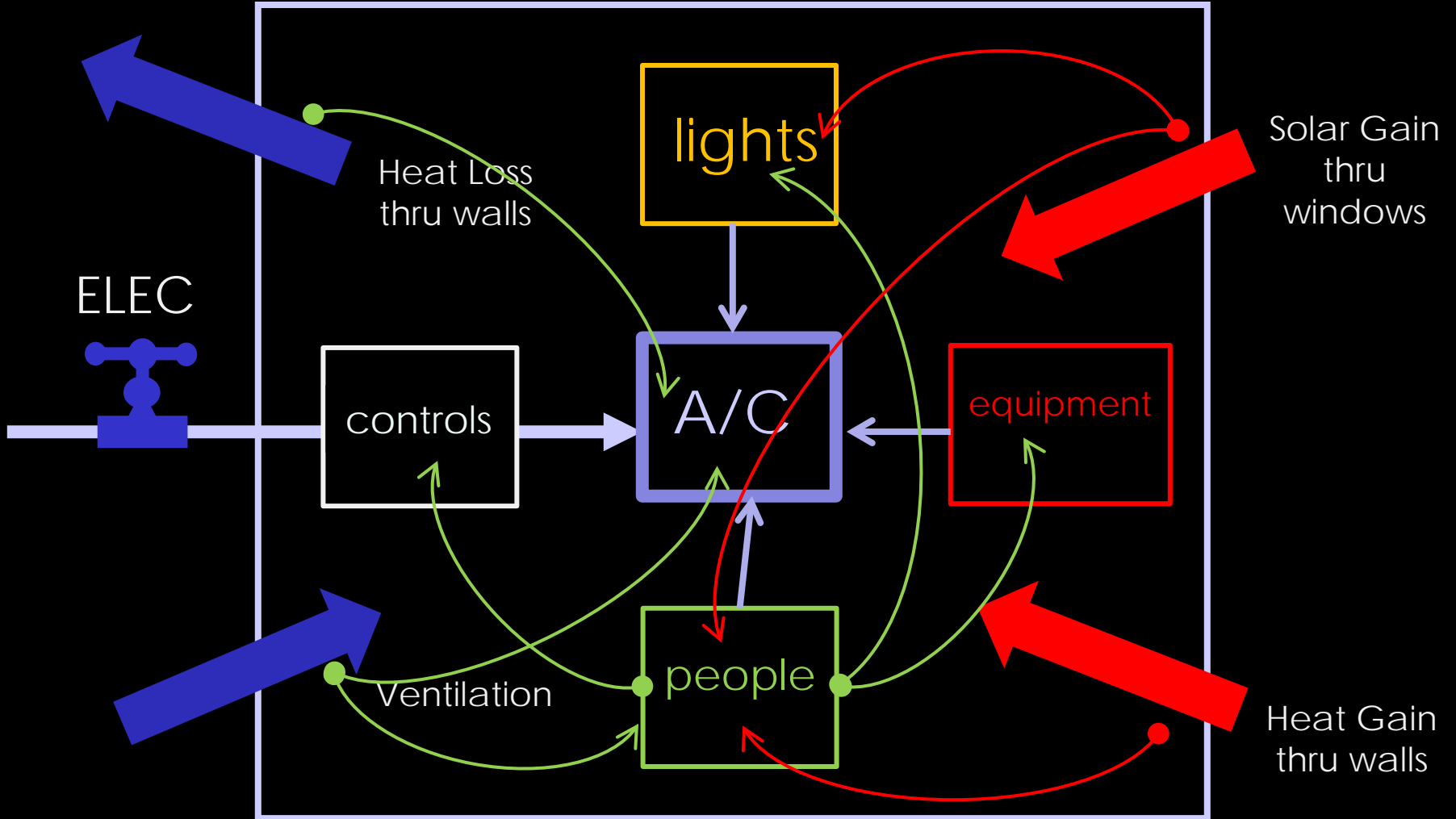

INTEGRATED APPROACH

1. Recognize building as a system – lighting, envelope, controls, HVAC are interrelated.
2. Address Indoor Environmental Quality (IAQ, lighting, acoustics, views, natural light)
3. Measurement & Verification

2011 EEB Hub Study: Disincentives for AER

1. Low-hanging fruit – easiest, shortest payback, lowest investment – often is single technology solution (not integrated).
2. Integrated solutions are complicated, slower, require thought/analysis, additional players – “slows the sale.”
3. There appear to be few integrated technology providers, even fewer integrated solution providers.

Owner's Dilemma

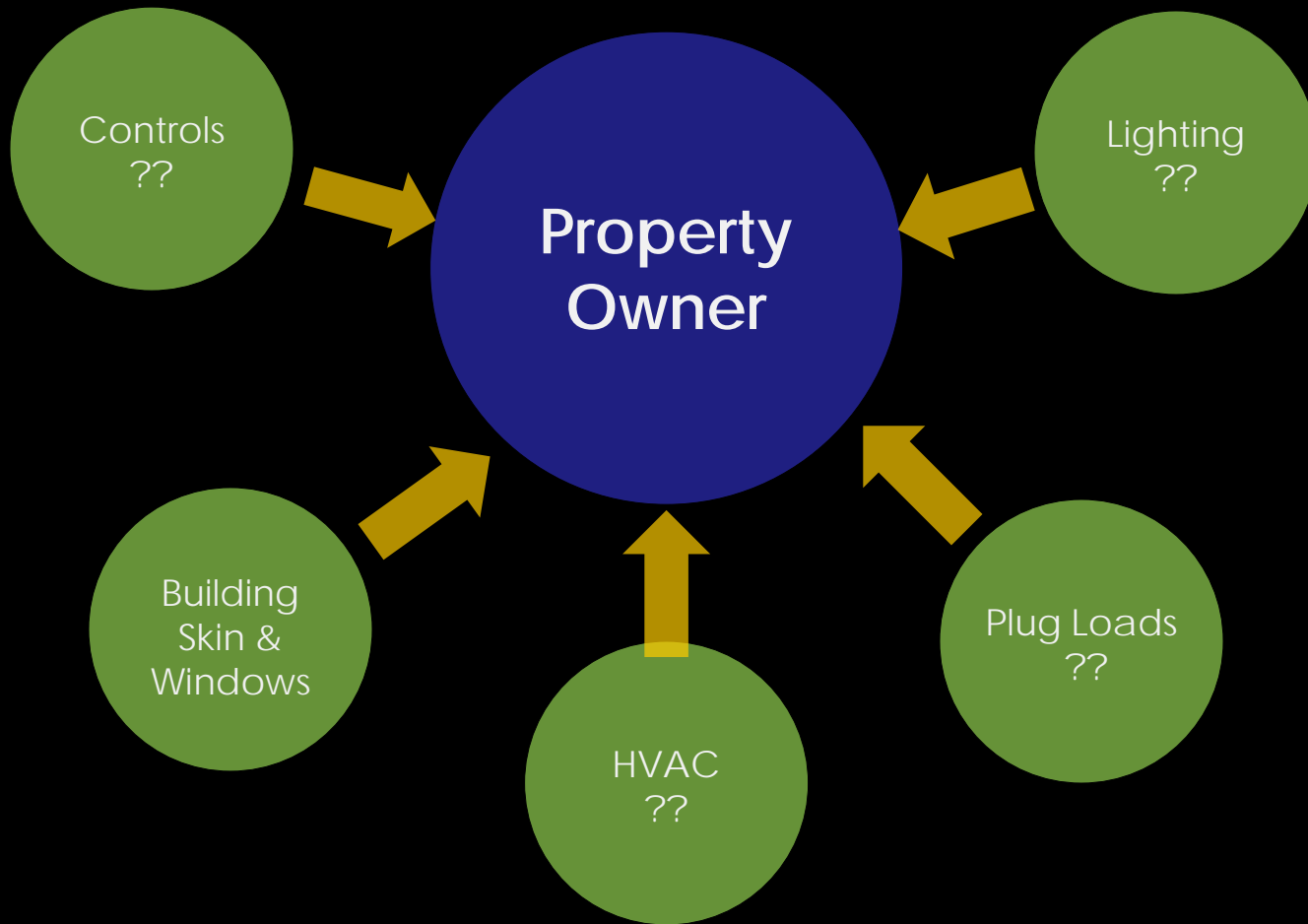

Major Determinant of Implemented Solutions



Major Determinant of Implemented Solutions

Whoever calls first

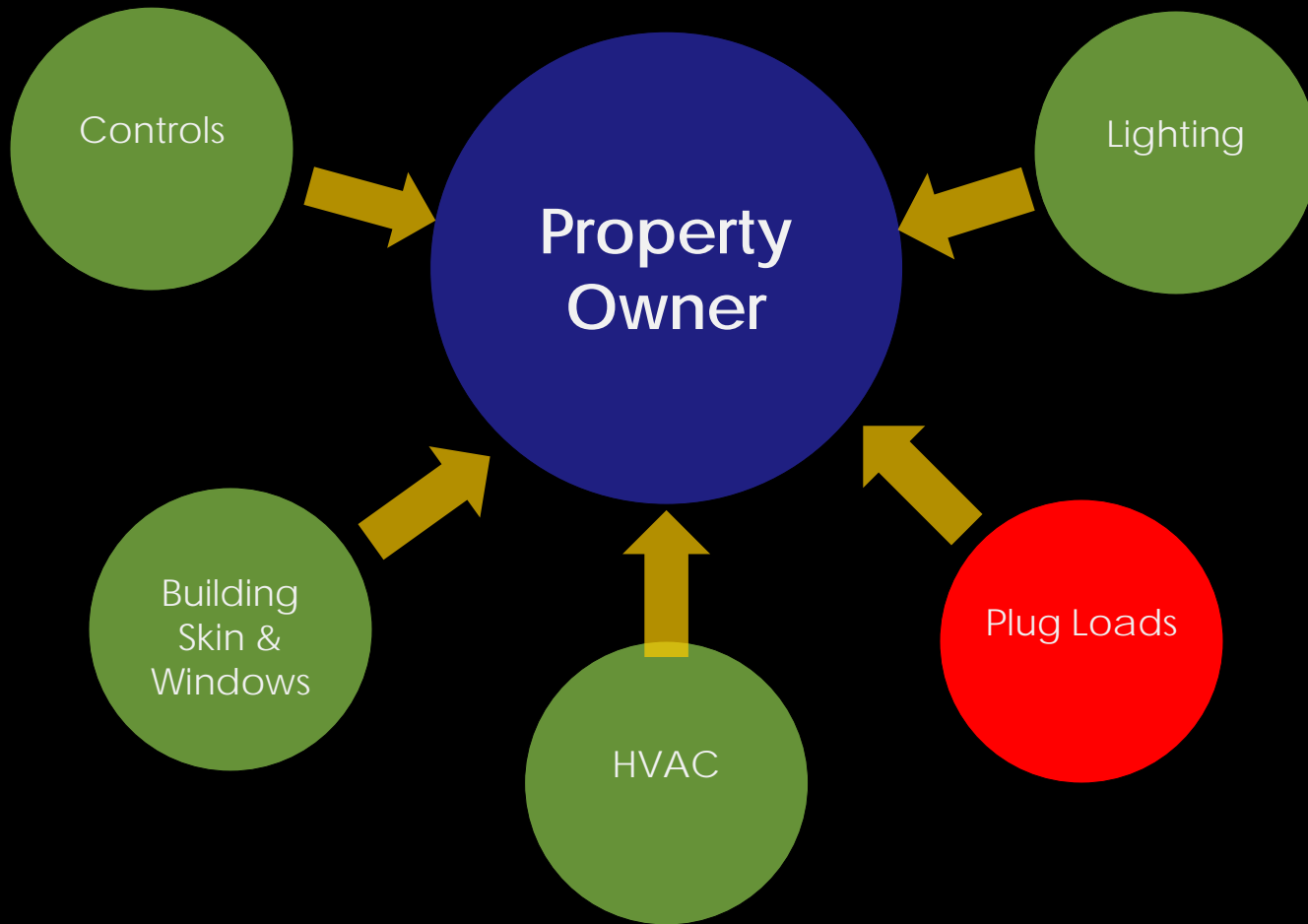

Major Determinant of Implemented Solutions

Whoever calls first

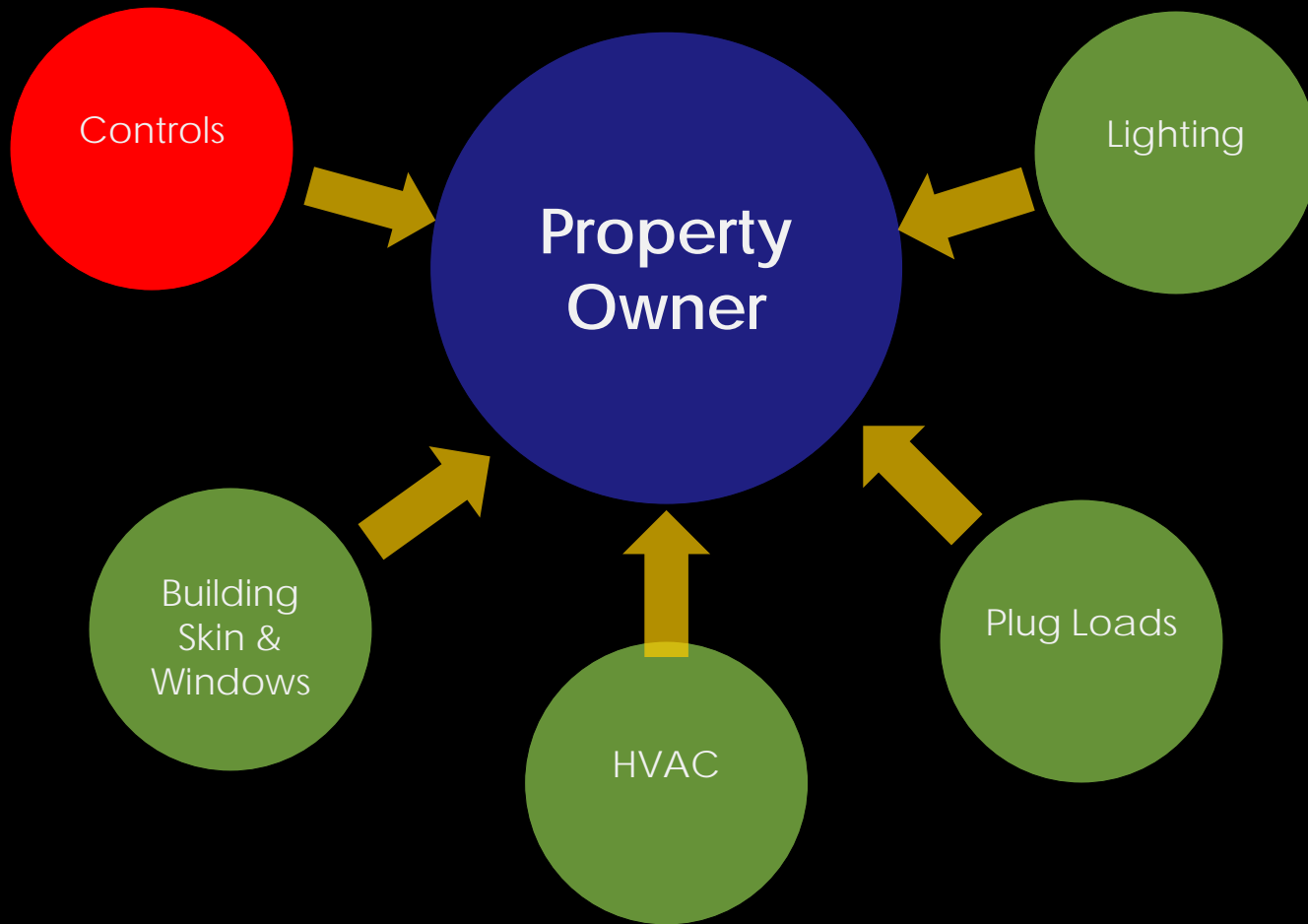

Major Determinant of Implemented Solutions

Whoever calls first

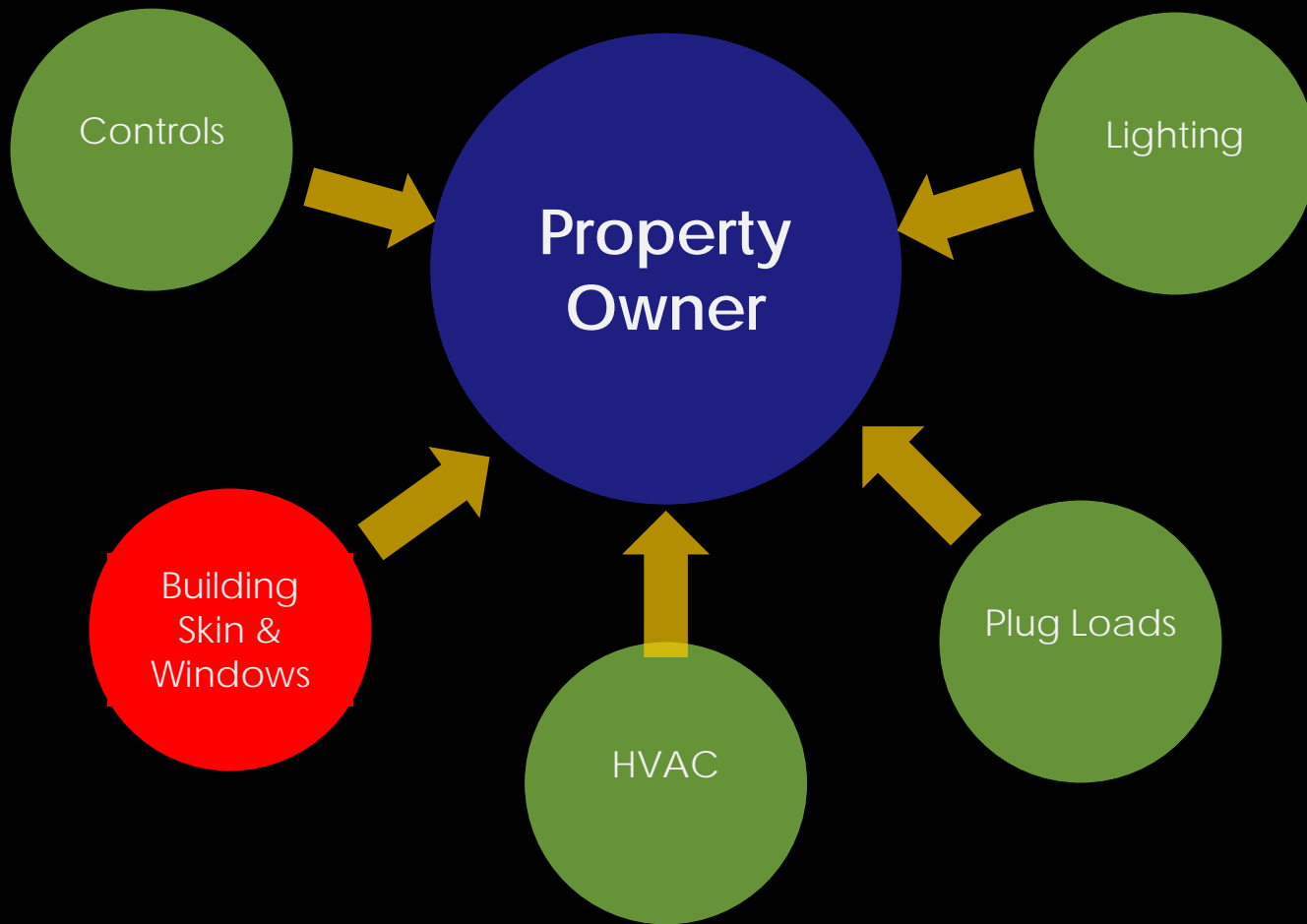

Major Determinant of Implemented Solutions

Whoever calls first

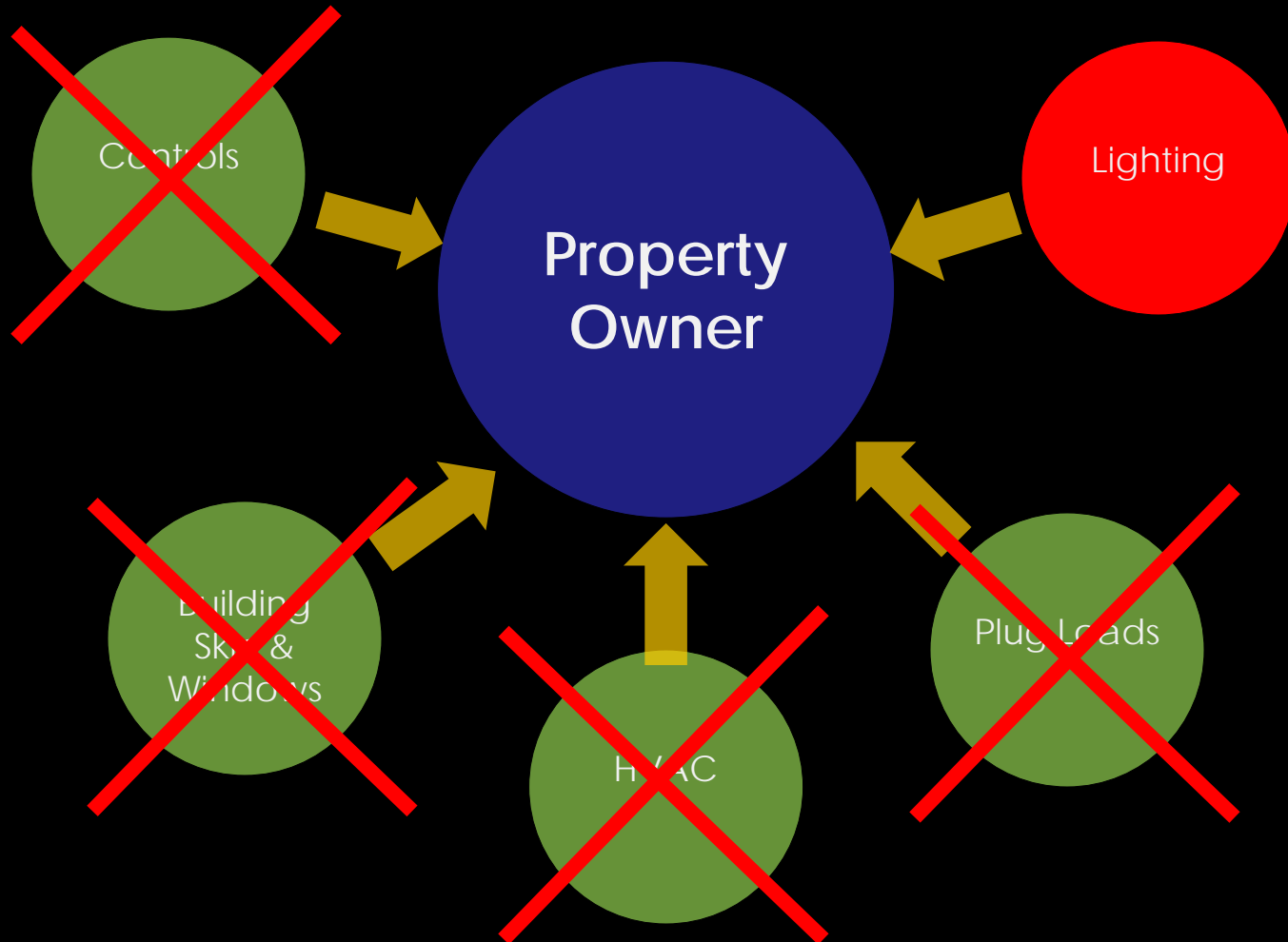

INTEGRATED IMPLEMENTATION PROVIDER

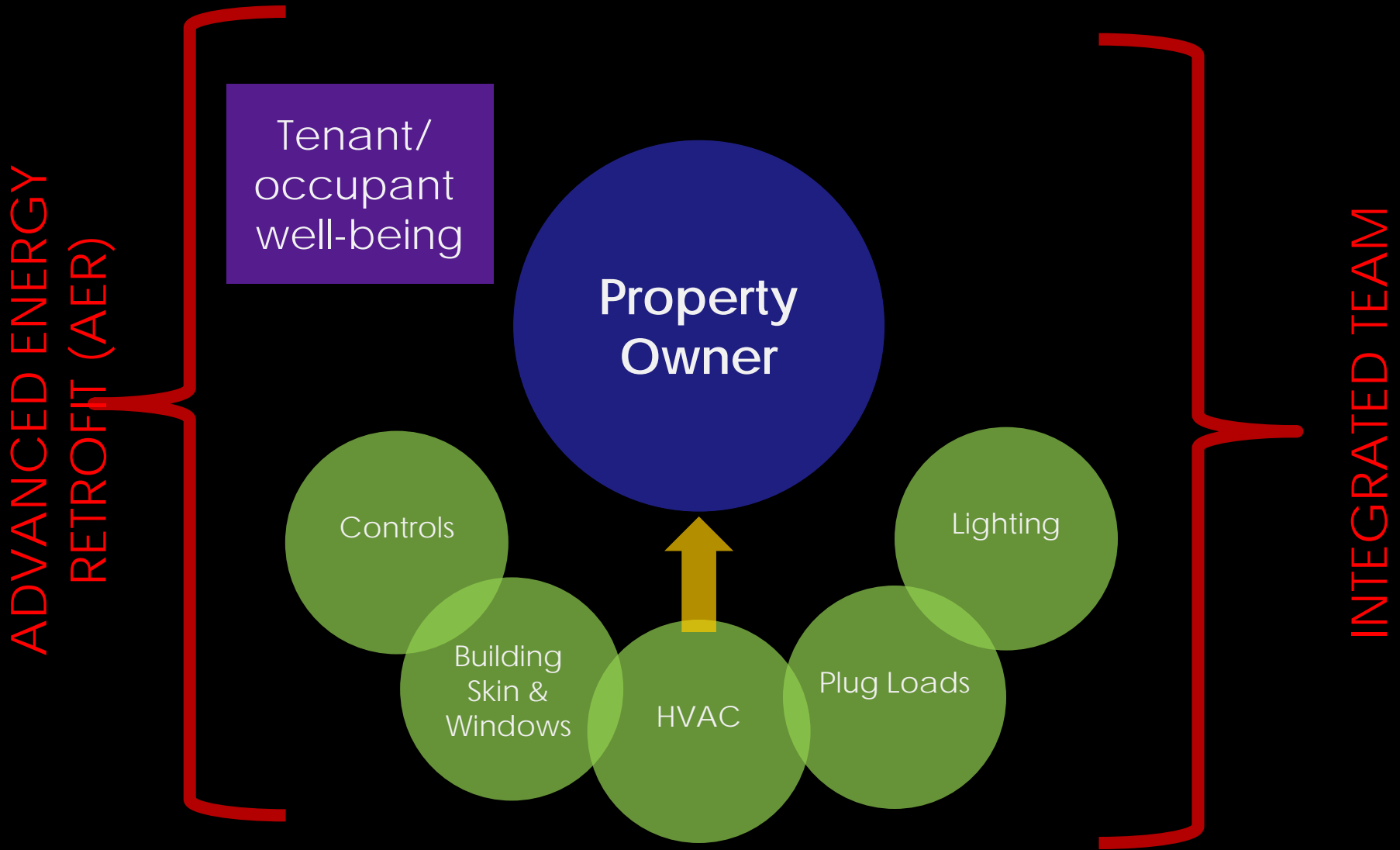

ADVANCED ENERGY RETROFIT (AER)

IDENTIFY THE MOST EFFECTIVE BUNDLE OF RENOVATIONS

- Integrated team – not single discipline/technology

TUNE IT UP

- Retro commissioning

DO IT IN THE RIGHT ORDER

- Small buildings may not be able to do it all at once
- AER “master plan” with recommended sequence

DON'T FORGET THE PEOPLE

- Indoor Air Quality, Daylight & Views, Acoustics

MEASUREMENT & VERIFICATION

- Indoor Air Quality, Daylight & Views, Acoustics

THE RFP WJZARD!

v1.0

YEAR TWO:

GOAL: Encourage the development of integrated retrofit delivery teams



- Create a standardized Request for Proposal for building owners.
- Require response by integrated team to evaluate energy efficient and healthy retrofits.
- Tailor the RFP by building typology.

THE RFP WIZARD!

v1.0

Target:

buildings smaller than 50,000 SF

- 73% of existing U.S. commercial buildings are less than 10,000 square feet
- 95% are less than 50,000 square feet (1/2 of all commercial floor area)
- These buildings cannot typically afford a full integrated design approach.

AVAILABLE INVESTMENT \$\$

3 yr. Simple Payback

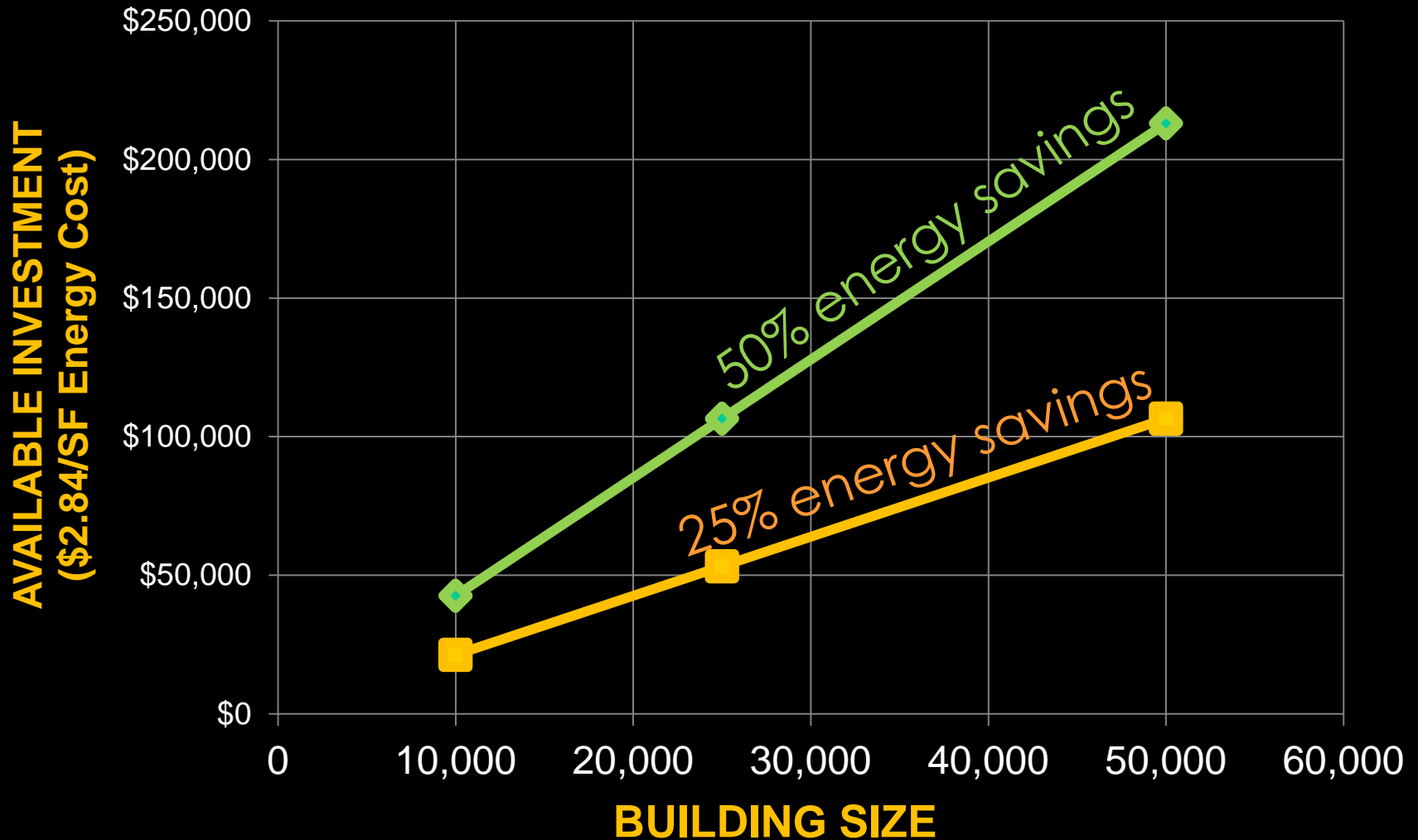

OUTPUT DETAIL

HUB
Guide

Energy
Star

RFP
Wizard

AUDIT
Level 1

AUDIT
Level 2

AUDIT
Level 3

LEVEL OF EFFORT / COST

Larger buildings can afford integrated design team who develop full integrated specs for retrofits.

In the small – medium size buildings, it will typically be “design-build” without a full team. The RFP Wizard can help provide the missing “integration” by

- *Requiring response from comprehensive team*
- *Providing input on sequence of implementation*
- *Providing input on inter-related systems*

RFP WIZARD

Basic structure

INPUTS

BLDG
INFO

BY OWNER



Wizard
Logic



OUTPUTS

RFP
SCOPE OF
WORK

RFP WIZARD

INPUTS

BASIC INFO

ENERGY COSTS

HVAC SYSTEM

BUILDING
ENVELOPE

LIGHTING

Wizard
Logic

OUTPUTS

RFP
SCOPE OF
WORK

RFP WIZARD – draft input form

RFP Wizard draft 

Basic Building Information

Address:

Street

City

State

Zip

When was the building first occupied?*

What is the total gross floor area of the building?*

How many stories above ground does the building have?*

What is the building use/type?*

HVAC Systems:

Heating-

When was the last heating system retrofit?*

How is heating provided?*

What type of heating control

RFP WIZARD

INPUTS

BASIC INFO

ENERGY COSTS

**DIRECT
FROM UTILITY**

HVAC SYSTEM

BUILDING
ENVELOPE

LIGHTING

Wizard
Logic
or
Energy
Model??

OUTPUTS

RFP
SCOPE OF
WORK

RFP WIZARD

INPUTS

OUTPUTS

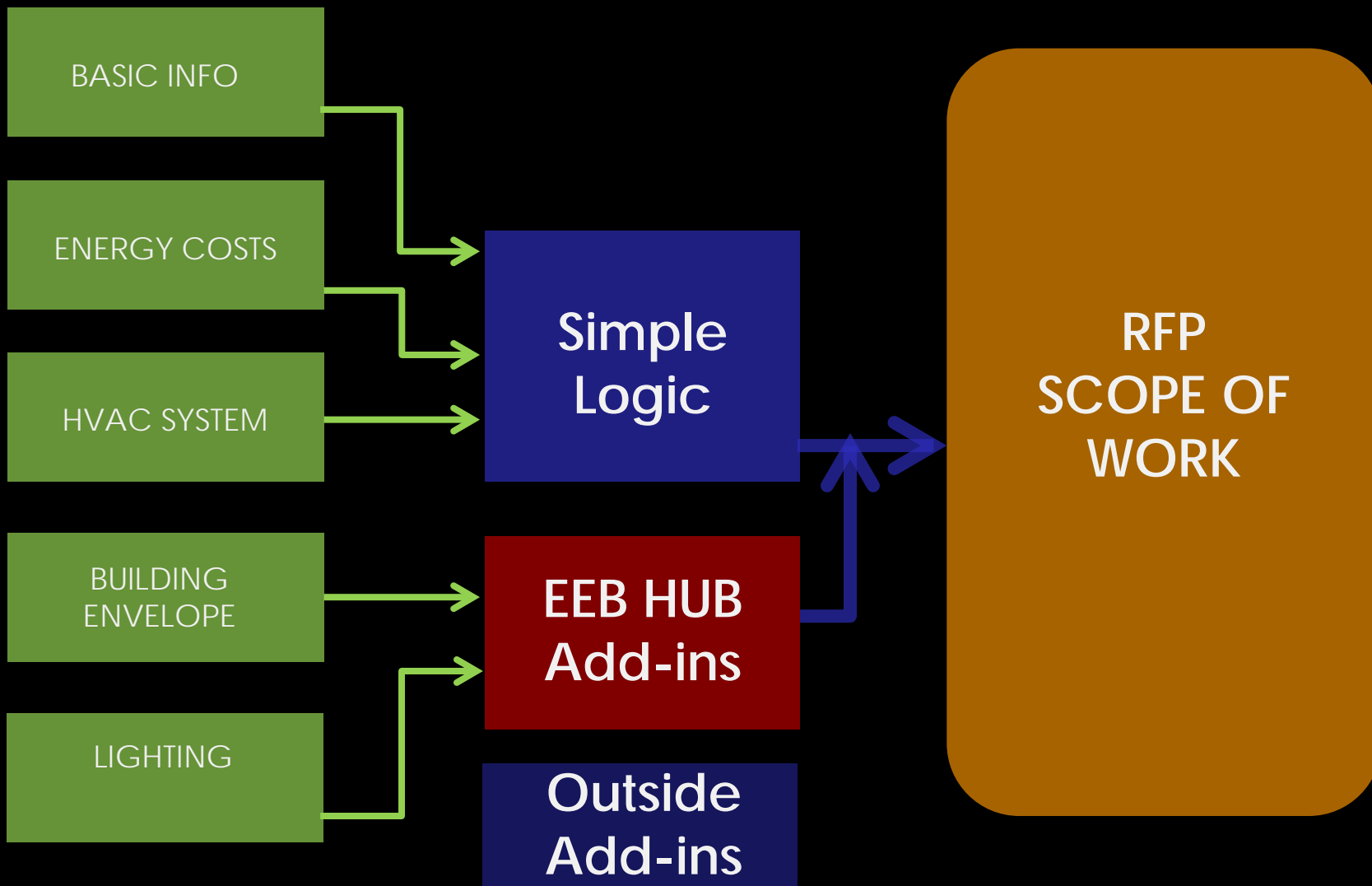

INPUTS

REQUIRED

NICE TO HAVE

FUTURE
IMPLEMENTATION

BASIC INFO

MONTHLY ENERGY
COSTS

HVAC SYSTEM

BUILDING
ENVELOPE

LIGHTING



RFP WIZARD

INPUTS

BASIC INFO

ENERGY COSTS

HVAC SYSTEM

BUILDING
ENVELOPE

LIGHTING

Wizard
Logic

OUTPUTS

RFP
SCOPE OF
WORK

RFP WIZARD – draft input form

RFP Wizard draft 

Basic Building Information

Address:

Street

City

State

Zip

When was the building first occupied?*

What is the total gross floor area of the building?*

How many stories above ground does the building have?*

What is the building use/type?*

HVAC Systems:

Heating-

When was the last heating system retrofit?*

How is heating provided?*

What type of heating control

Input questionnaire instrument developed in Adobe Forms.
Would be linked from EEB Hub website

RFP WIZARD – draft input form

The screenshot displays the FORMSCENTRAL RFP Wizard interface. The top navigation bar includes tabs for Design, Options, Test, Distribute, View Responses (selected), and Summary Report. Below the navigation bar is a rich text editor toolbar with options for font face (Myriad Pro), size (12), bold, italic, underline, and text color. A table titled 'All Responses' is shown with columns for Time Submitted, Street, City, and State. A context menu is open over the table, listing actions such as New, Open..., Close, Saved Automatically, Rename..., Export Responses... (highlighted), Download Selected Response as PDF Form..., Save as PDF Form..., Share..., Copy Fillable Form Link..., Test Form (Ctrl-M), Reset Dialog Warnings, Page Setup..., and Print....

	A	B	C	D
	Time Submitted	Street	City	State
1	October 18, 2012 12:54 PM	1601 Broadway St.	Vancouver	WA
2	August 28, 2012 11:55 AM			
3	August 28, 2012 10:53 AM			1945-1975
4	August 28, 2012 10:39 AM			1945-1975

We have begun working with NBI to insure that we are collecting data readable by FirstView tool.

RFP WIZARD – sample building

- 10,000 SF commercial office building
- Philadelphia, PA
- 3 stories
- Brick masonry construction,
- Built in 1935
- Building and HVAC system renovated 1980
- Lighting upgraded 2004.

RFP Wizard draft 

Basic Building Information

Address:

Street

City

State

Zip

When was the building first occupied?

What is the total gross floor area of the building?

How many stories above ground does the building have?

What is the building use/type?

RFP WIZARD – FirstView Output

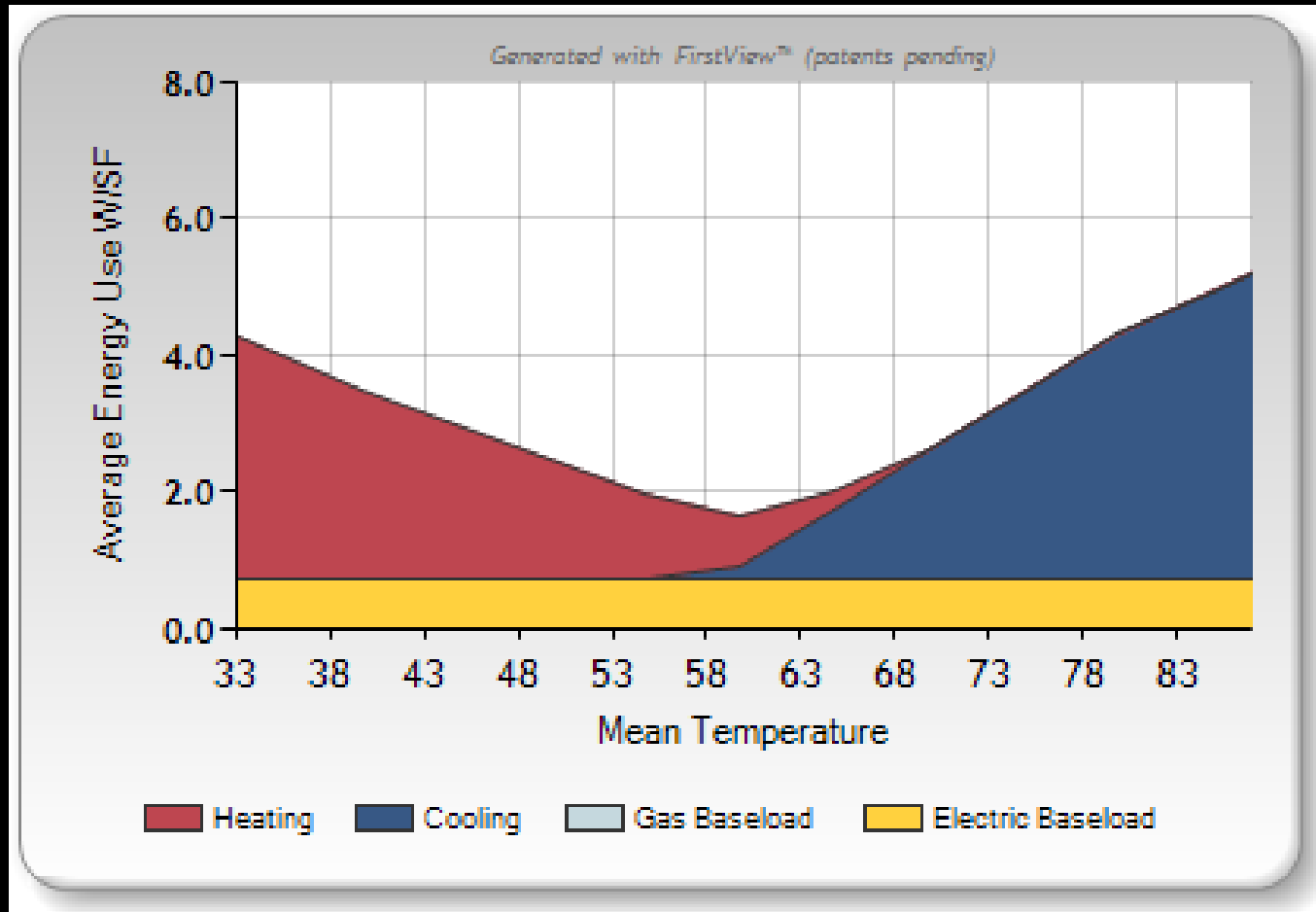

Energy use by temperature

RFP WIZARD – FirstView Output

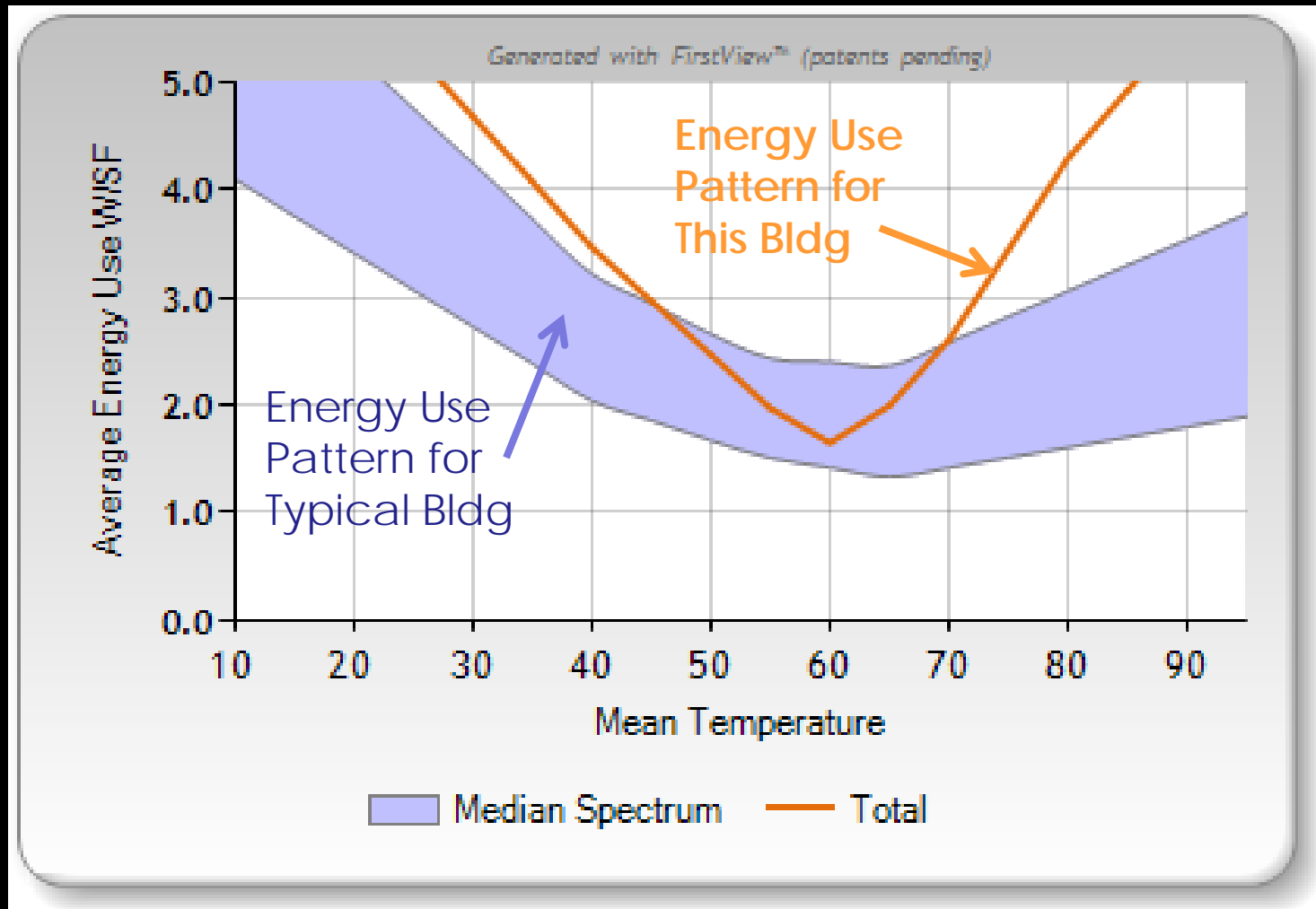

Energy Signature benchmarked to Average Building

AER Recommendation Logic

combines FirstView data plus additional input from Hub form

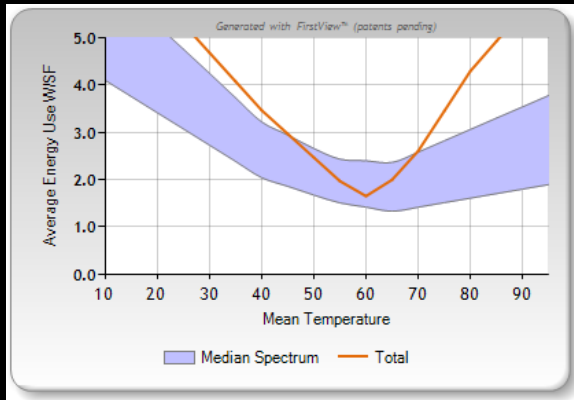

Energy Use Pattern for building shows high correlation to temperature change. Given age of building, this suggests the building envelope is a weak point.

Higher than average heating & cooling usage together with age of systems suggests upgrade of boiler and A/C should be considered.

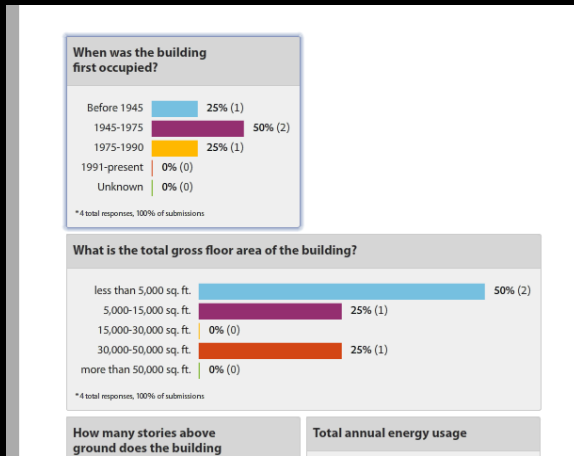

Low base electric load and relatively recent lighting upgrade suggest lighting not big opportunity but office use and building geometry suggest daylighting controls may have potential.

Old controls system suggest upgrading to new controls worth considering.

RFP WIZARD – sample building AER Scope of Work

ECM's to investigate

- Building Envelope – wall and roof insulation
- Building Envelope – window replacement
- Building Envelope – general building sealing*
- *Ventilation – consider providing mechanical ventilation with heat recovery for improved IAQ
- Heating System – consider upgrading
- Cooling System - consider upgrading
- Lighting – consider daylight controls in areas within 20' of exterior windows

RFP WIZARD

AER Scope of Work

INTEGRATED TEAM Proposal must include the following expertise:

- HVAC
- Controls
- Building Envelope
- Indoor Air Quality
- Lighting/Daylighting

RFP WIZARD

AER Scope of Work

AER Master Plan

- Phasing
- Recommended Order of Implementation

Potential Additional Scope

- Retro commissioning of selected systems
- Cost/benefit analysis of selected ECM's

RFP WIZARD

INPUTS

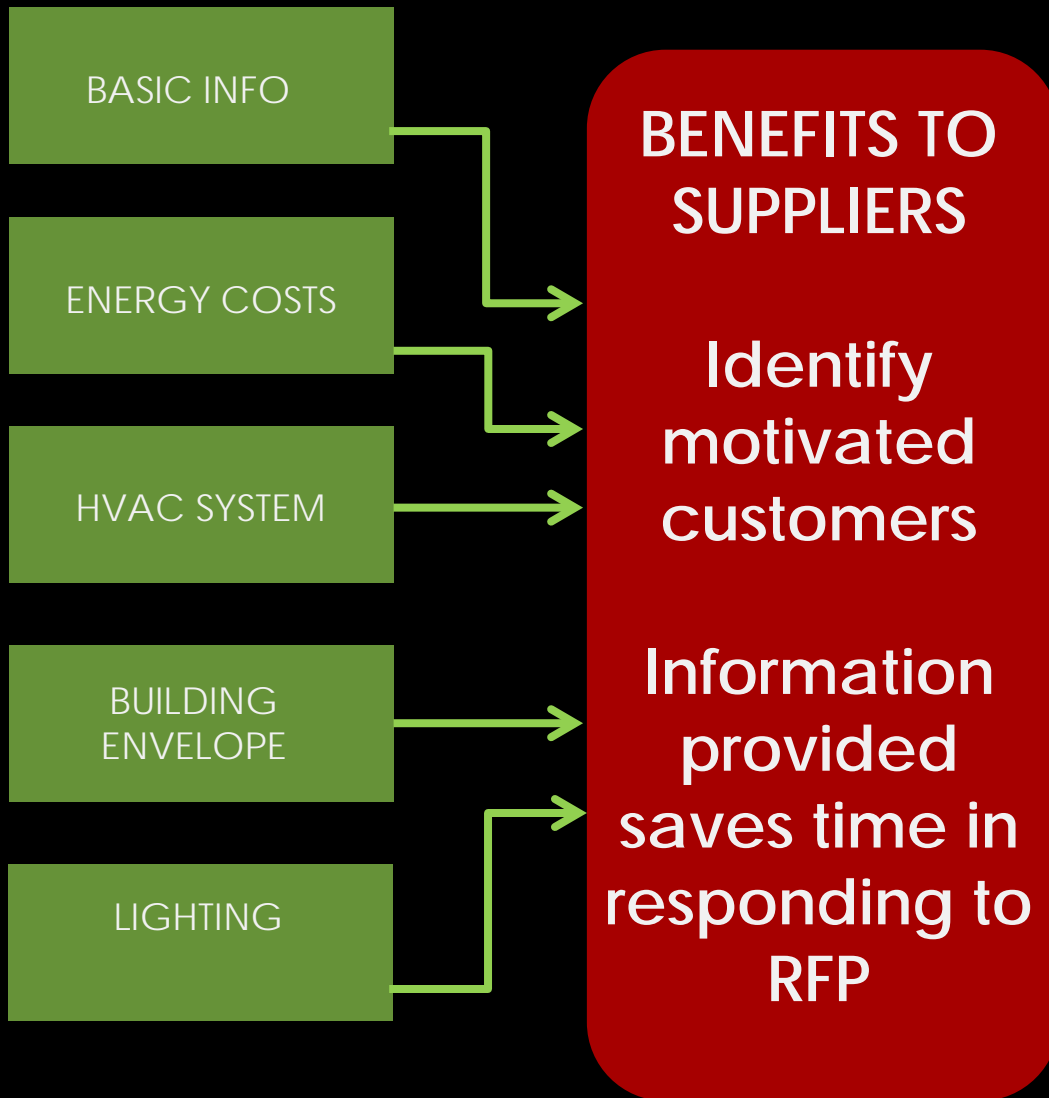

RFP WIZARD

**BENEFITS TO
OWNERS**

**Competitive
proposals**

**Apples to
Apples
comparison**

**Full AER
scope
included**

THE RFP WIZARD!

v1.0

QUESTIONS

1. Would you be willing would you be to respond to an RFP similar to the ones we've shown today? If the answer is NO, why?
2. How can we modify the RFP tool to make it more likely you would respond.
3. Is there additional information you'd like to get about the building beyond what we've discussed.

THANKS!!

